

Standard Truck Specifications

Specifications		KBZ						
		FD45T	FD50TS	FD50TF				
1	Manufacturer							
2	Model	FD45T	FD50TS	FD50TF				
3	Load capacity	kg	4500	5000	5000			
4	Load center	mm	600	500	600			
5	Power unit	Diesel						
6	Operator type	Driver/seat						
7	Type tire	front/rear	Pneumatic					
8	Wheels	front/rear	2/2					
Dimension		9	Max. Lifting height	mm	3000			
		10	Free lift	mm	140			
		11	Fork size	L × W × T	mm	1220 × 150 × 50	1070 × 150 × 50	1220 × 150 × 60
		12	Tilt angle	mast forward/backward	deg	6/12		
		13	Overall length(without fork)	mm	3183		3422	
		14	Total width	mm	1485			
		15	Mast height(fork lowering)	mm	2300	2360		
		16	Overall height fork raised(with backrest)	mm	4143			
		17	Height to head guard	mm	2270			
		18	Turning radius(outside)	mm	2860	3100		
19	Load distance(fork front face to front axle)	mm	560					
20	Right angle stacking aisle	mm	4668	4910				
Performance		21	Speed	full load/no load	km/h	18/19		
		22	Lifting speed	full load/no load	mm/s	410/430		440/600
		23	Lowering speed	full load/no load	mm/s	520/490		
		24	Max. Drawbar pull	power shift T/M full load/no load	kg	4500/2000		
		25	Gradeability at 1.6km/h	power shift T/M full load/no load	%	25		
Weight		26	Truck weight	kg	7483		7530	
		27	Weight distribution	no load	front axle	kg	2750	3390
					rear axle	kg	4733	4140
				full load	front axle	kg	10263	10910
rear axle	kg	1720	1573	1410				
Chassis & Wheels		28	Tire model	front/rear	300-15-18PR / 7.00-12-12PR			
		29	Wheelbase	mm	2000		2200	
		30	Tread	front/rear	mm	1180 / 1190		
		31	Ground clearance	mast/frame	mm	100 / 240		
		32	Brake	Hydraulic power brake				
Drive line		33	Engine	model	YTO4108	MITSUBISHI S6S	MITSUBISHI S6S	
				rated power	KW/rpm	57/2200	52/2300	52/2300
				rated torque	N·m/rpm	297/1600	248/1700	248/1700
				number of cylinder		4	6	6
		displacement	L	4.578	4.996	4.996		
34	Fuel tank capacity	L	80					
35	Transmission type	hydraulic torque transmission						
36	Transmission	front/rear-transmission type	power shift T/M	2/1 - electromagnetic hydraulic				
37	hydraulic operating pressure	hydraulic system pressure	kg/cm ²	200				

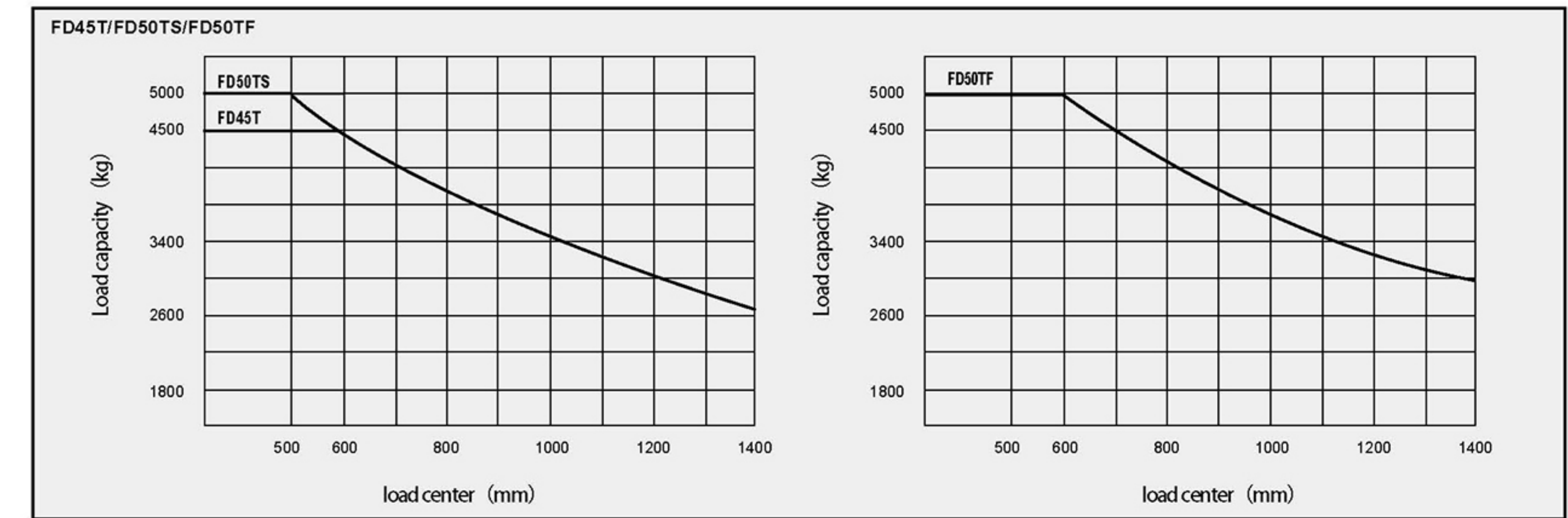

Notes:

Vertical axis represents load capacity; horizontal axis shows load center, load center is determined from front face of the fork.

Capacity is based on a 1000mm cube load configuration with the center of gravity at the true center of the cube, and standard fork.

The load capacity will be reduced while the mast tilts forward or loads with long fork or lifts transformable width of goods.

The load capacities at the various load centers can be known timely via the load curve.

KBZ's products and specifications change without prior notice.

KBZ forklift truck has equipped with standard safety device.

KBZ is not responsible for the damage occurred by removing its safety device.

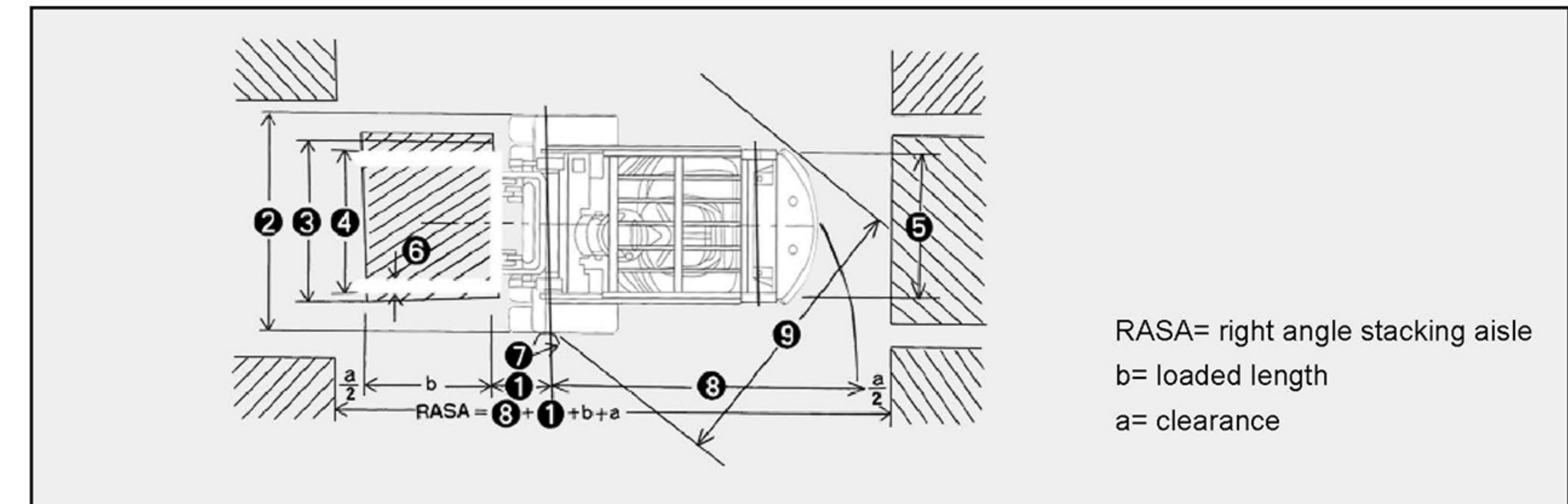

型号	FD45T	FD50TS	FD50TF
① Front overhang	560	560	590
② Total width	1485	1485	1485
③ Front track	1180	1180	1180
④ Fork spread(outside)	300~1370	300~1370	300~1370
⑤ Rear track	1190	1190	1190
⑥ Fork width	150	150	150
⑦ Turning radius(inside)	280	280	280
⑧ Turning radius(outside)	2860	2860	3100
⑨ Right angle turning aisle	4668	4668	4910

Standard equipments:

●wide view mast ●cyclone air cleaner ●load one-way valve ●preheat indicator ●king pin ●engine-start switch ●standard backrest ●long-life tires ●overhead guard ●oil and water separator ●power steering ●adjustable steering column ●radiator water tank ●side roller ●standard carriage ●oil temperature cooler ●headlamp and steering indicator lamp ●charge indicator lamp ●hour meter ●oil warning light of engine ●water temperature gauge ●fuel gauge ●backward driving light ●electric horn ●neutral-safety switch ●rear mirror ●tools ●backward driving buzzer ●general seat

Options:

●fire extinguisher ●cab ●heater unit ●rear work light ●solid tires ●fireproof muffler ●upper exhaust pipe ●tilt cylinder sheath ●rotating warning light ●LPG conversion system ●pre-filtration air intake device

Attachments:

●side shifter ●fork positioner ●carpet boom ●fork extension ●longer fork ●Flat clamp ●others

Wide view mast VM

Model	Load center			Max. lifting height	Mast height				Free lift (with backrest)	Free lift (without backrest)	Tilt angle	Weight		
	600mm	500mm	500/600mm		Fork lowered		Fork lift (with backrest)							
	FD45T	FD50TS	FD50TF		FD45T	FD50T/S/F	FD45T	FD50T/S/F						
	kg	kg	kg	mm	mm	mm	mm	mm	mm	angle	kg	kg	kg	
VM300	4500	5000	5000	3000	2240	2365	4205	4360	140	140	6 - 12	7230	7230	7830
VM350	4500	5000	5000	3500	2490	2615	4705	4860	140	140	6 - 12	7293	7293	7893
VM400	4500	5000	5000	4000	2790	2915	5205	5360	140	140	6 - 6	7407	7407	8007
VM450	4500	5000	5000	4500	3040	3165	5705	5860	140	140	6 - 6	7471	7471	8071
VM500	4500	4500 + 4800	5000	5000	3290	3415	6205	6360	140	140	6 - 6	7534	7534	8134
VM550	4000 + 4400	4000 + 4800	4000 + 4800	5500	3590	3715	6705	6860	140	140	3 - 6	7610	7610	8210
VM600	3550 + 4000	3550 + 4000	3350 + 4000	6000	3840	3965	7205	7360	140	140	3 - 6	7711	7711	8311

2 Stage free lift mast VFM

Model	Load center			Max. lifting height	Mast height				Free lift (with backrest)	Free lift (without backrest)	Tilt angle	Weight		
	600mm	500mm	500/600mm		Fork lowered		Fork lift (with backrest)							
	FD45T	FD50TS	FD50TF		FD45T	FD50T/S/F	FD45T	FD50T/S/F						
	kg	kg	kg	mm	mm	mm	mm	mm	mm	angle	kg	kg	kg	
VFM250	4000	5000	5000	2500	1990	2115	3705	3860	755	1175	6 - 12	7114	7114	7714
VFM270	4000	5000	5000	2700	2090	2215	3905	4060	855	1280	6 - 12	7180	7180	7780
VFM300	4000	5000	5000	3000	2190	2315	4205	4360	955	1425	6 - 12	7200	7200	7800
VFM350	4000	5000	5000	3500	2490	2615	4705	4860	1255	1675	6 - 12	7220	7220	7820
VFM375	4000	5000	5000	3750	2615	2740	4955	5110	1380	1800	6 - 12	7280	7280	7880
VFM400	4000	5000	5000	4000	2790	2915	5205	5360	1555	1925	6 - 6	7305	7305	7905
VFM450	4000	5000	5000	4500	3040	3165	5705	5860	1805	2176	6 - 6	7335	7335	7935
VFM475	4000	4000 + 4500	5000	4750	3165	3290	5955	6110	1930	2376	6 - 6	7380	7380	7980
VFM500	4000	4000 + 4300	5000	5000	3290	3415	6205	6360	2055	2426	6 - 6	7455	7455	8055
VFM550	3200 + 3900	3200 + 3900	4000 + 4800	5500	2945	3070	6705	6860	1710	2676	3 - 6	7505	7505	8105
VFM600	2500 + 3700	2500 + 3700	3350 + 4000	6000	3195	3320	7205	7360	1960	2926	3 - 6	7655	7655	8255

3 Stage free lift mast VFHM

Model	Load center			Max. lifting height	Mast height				Free lift (with backrest)	Free lift (without backrest)	Tilt angle	Weight		
	600mm	500mm	500/600mm		Fork lowered		Fork lift (with backrest)							
	FD45T	FD50TS	FD50TF		FD45T	FD50T/S/F	FD45T	FD50T/S/F						
	kg	kg	kg	mm	mm	mm	mm	mm	mm	angle	kg	kg	kg	
VFHM360	4500	4900	4800	3600	1975	2055	4805	4960	695	1085	6 - 12	7580	7580	8180
VFHM400	4500	4900	4800	4000	2110	2190	5205	5360	830	1220	6 - 12	7640	7640	8240
VFHM435	4500	4700	4800	4350	2225	2305	5555	5710	945	1335	6 - 6	7420	7420	8460
VFHM480	4500	4600	4800	4800	2375	2455	6005	6160	1095	1485	6 - 6	7500	7500	8540
VFHM500	4400	4000	4700	5000	2475	2555	6205	6360	1195	1585	6 - 6	7560	7560	8600
VFHM540	3300 + 4300	3400 + 4300	3500 + 4600	5400	2600	2680	6605	6760	1320	1710	6 - 6	7720	7720	8760
VFHM550	3200 + 4200	3200 + 4200	3300 + 4500	5500	2640	2720	6705	6860	1380	1750	3 - 6	7740	7740	8780
VFHM600	2400 + 3900	2900 + 4100	2900 + 4300	6000	2825	2905	7205	7360	1545	1935	3 - 6	7820	7820	8860
VFHM650	* 3300	* 3400	* 3600	6500	3045	3125	7705	7860	1765	2155	3 - 6	7880	7880	8920
VFHM700	* 2900	* 3000	* 3000	7000	3210	3290	8205	8360	1930	2320	3 - 6	7880	7880	8920

Note: The mark of * is with double tires.



KBZ has passed ISO9001 quality system certification



FD Series 45-50 Counter Balanced Forklift



Three Features

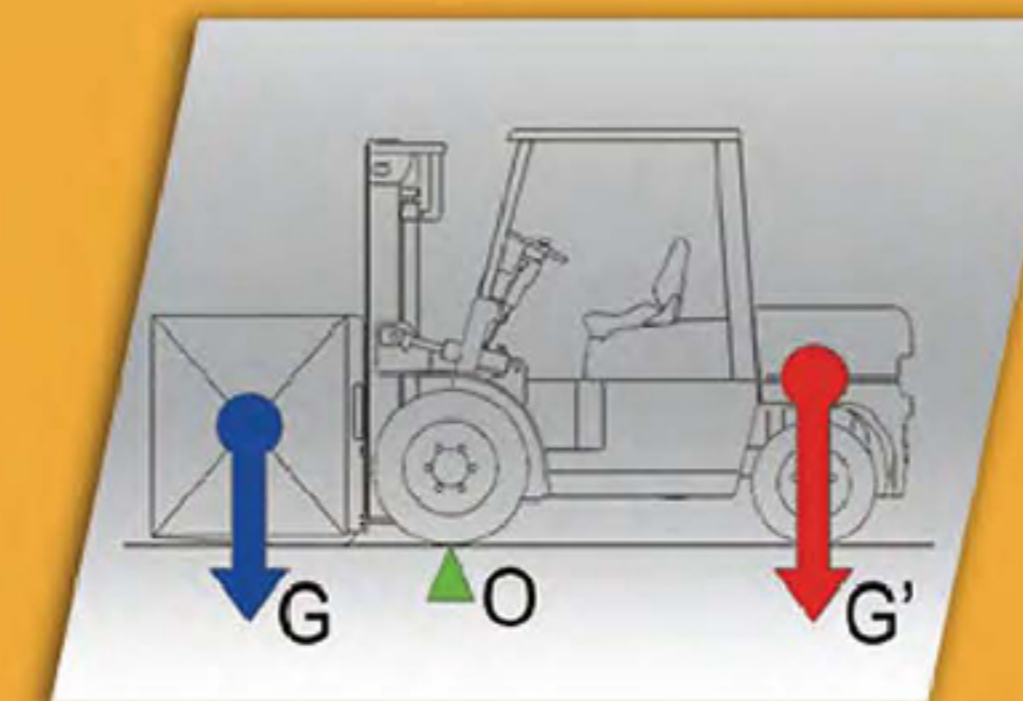

1 High safety factor

Compared with the similar forklift its balance weight increases more than 300kg, the stability and overloading are much more improved.

2 Powerful braking

Strong and effective power braking system provides the security assurance. Optimized designed and prior system, keeps the power distribution of other systems while ensuring the braking. This makes operation more comfortable.



3 Powerful and effective environmental engine

With powerful and effective environmental engine, applied to National stage III and EURO III emission standard.

